

PRODUCT DATA

COMBI 302 POLAR / COMBI 302 POLAR TOP BY NILAN



Ventilation with passive & active heat recovery



Domestic



Passive
heat recovery



Active
heat recovery



Ventilation
<350 / 430 m³/h



Comfort
heating



Comfort
cooling

COMBI 302 POLAR

Product description

Combi 302 Polar is a ventilation unit that combines two heat recovery technologies.

Passive heat recovery takes place via a counterflow heat exchanger that utilises between 85% and 95% of the energy in the extracted air. Active heat recovery takes place via a heat pump that utilises the residual energy. The heat pump has a COP >4, which eliminates the need to install a heating coil with an attached mixing circuit. Combi 302 Polar can increase the temperature of the supply air to over 30°C.

The heat pump also makes it possible to cool the supply air in the summer by up to 10°C. Due to the low air exchange, this does not function as an air conditioning system, but cooling the air intake reduces its humidity, giving a more pleasant and comfortable climate inside the home, even when the indoor temperature is high.



Combi 302 Polar is delivered with a built-in pre-heating element, which protects the counterflow heat exchanger against icing. This ensures continuous operation at low outdoor temperatures.

Efficient counterflow heat exchanger providing high temperature efficiency and low pressure loss, resulting in good heat recovery and low energy consumption.

An automatic 100% bypass damper leads the outdoor air past the heat exchanger when heat recovery is not required, thereby saving energy.

The efficient fans are powered by energy-saving EC motors.

They provide a constant air volume with a four-step adjustment.

The hermetically-sealed heat pump utilises the residual energy after the counterflow heat exchanger and ensures a high supply air temperature.

Can also cool the supply air.

The powder-coated condensate drain prevents the formation of "acid water" and allows the condensate to be drained away.

Intelligent humidity sensors provide an option for controlling the ventilation as required, based on the average air humidity in the home.

A CO₂ sensor can be purchased as an accessory.

The unit comes with a clear and user-friendly HMI Touchpanel.

The modern HMI Touchpanel runs Modbus communication.

Filter monitor with timer. Separate door for the filters give the user easy access to change the filter and also protect the user from contact with fans and heat pump.

Alu zinc steel plate, white powder coating (RAL9016)

Combi302 Polar has an integral frost-protection heating element.

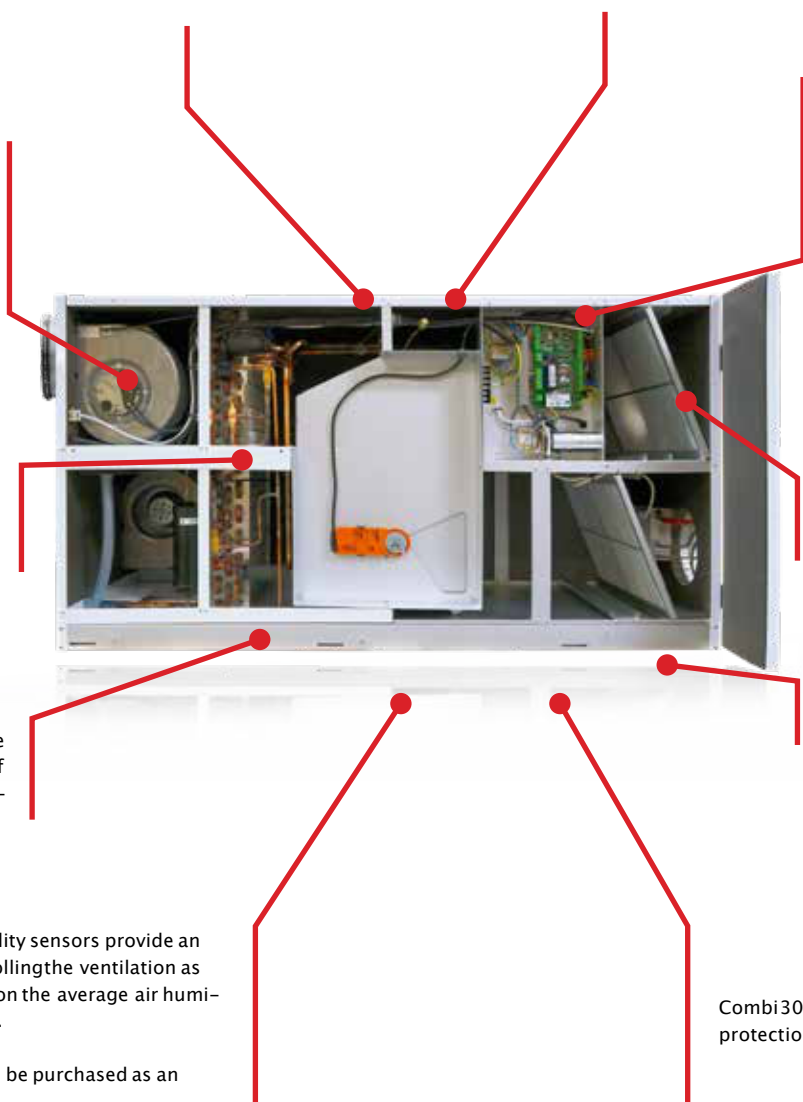

Separate door for the filters give the user easy access to change the filter



TECHNICAL SPECIFICATIONS

Combi 302 Polar

Dimensions (W xD xH)	1300 x580 x 700 mm
Weight	83 kg
Plate type casing	Aluzinc steel plate, white powder coatingRAL9016
Heat loss casing (*1)	32 W /-32W
Heat exchangertype	Polystyrene counterflow heat exchanger
Compressor type	Piston compressor
Fan type	EC,constant volume
Filter class	ISO Coarse >90%(G4)
Duct connections	Ø 160 mm
Condensate drain	PVC, Ø 20x1,5 mm
External leakage (*2)	<1.1 %
Internal leakage (*3)	<1.8 %
Refrigerant	R134a
Refrigerant filling	0.7 kg

Supply voltage	230 V (±10%),50/60 HZ
Max.input/power	1.2 kW / 5.2 A
Tightness class	IP31
Standby power	3.2W
Power consumption build-in preheating element	0.6 kW
Ambient temperature	-20 / +40°C

*1 32 W: Outdoor air temperature -12°C. Fitting location -12°C.
Extract air temperature 20 °C (room).
-32W: Outdoor air temperature -12°C. Fitting location 20 °C.
Extract air temperature 20 °C (room).

*2 At ±250 Pa and 300 m³/h according to EN 13141-7.

*3 At ±100 Pa and 300 m³/h according to EN 13141-7.

Dimensional drawing

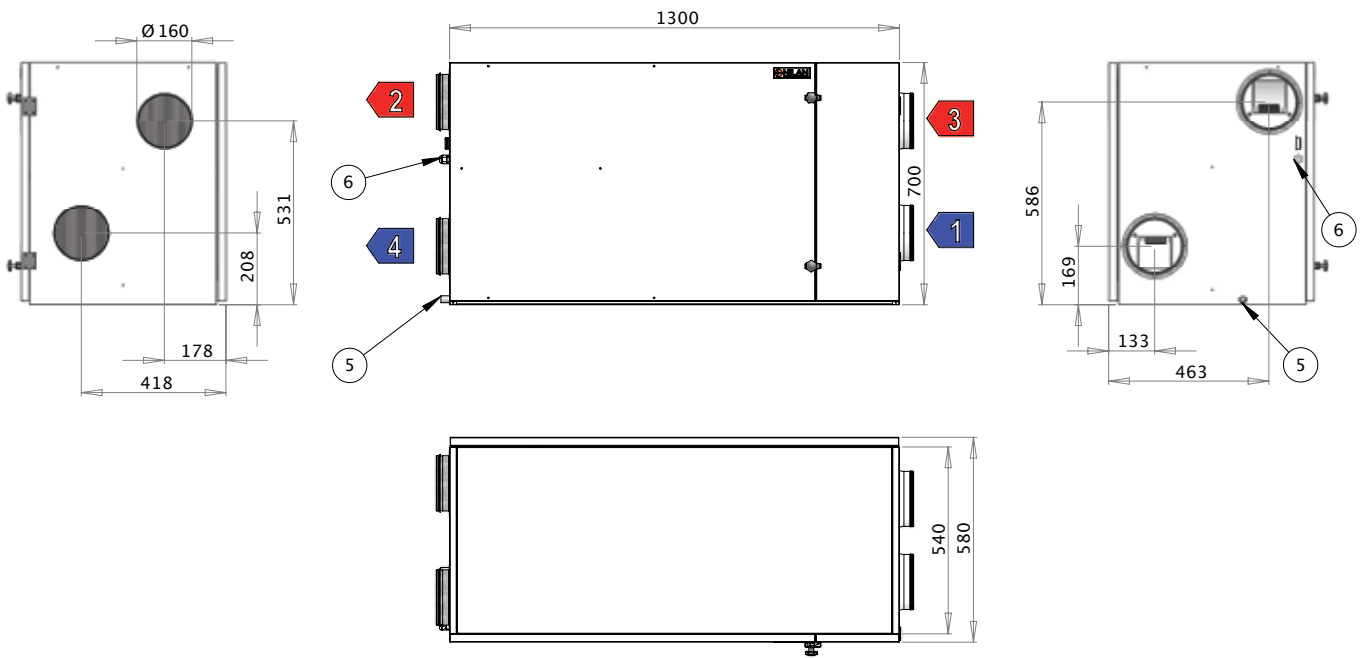

All dimensions are in mm.

Connections

- 1: Fresh air
- 2: Supply air
- 3: Extract air
- 4: Discharge air
- 5: Condensate drain
- 6: Electric supply

PLANNING DATA

Capacity

Capacity of standard unit as a function of q_v and $P_{t,ext}$.

SEL values according to EN 13141-7 are for standard units with ISO Coarse >90% (G4) filters and without heating element.

SEL values comprise the unit's total power consumption incl. control.

$$\frac{J/m^3}{3600} = W/m^3/h$$

Conversion factor:

Attention! The SEL values are measured and stated as a total value for both fans.

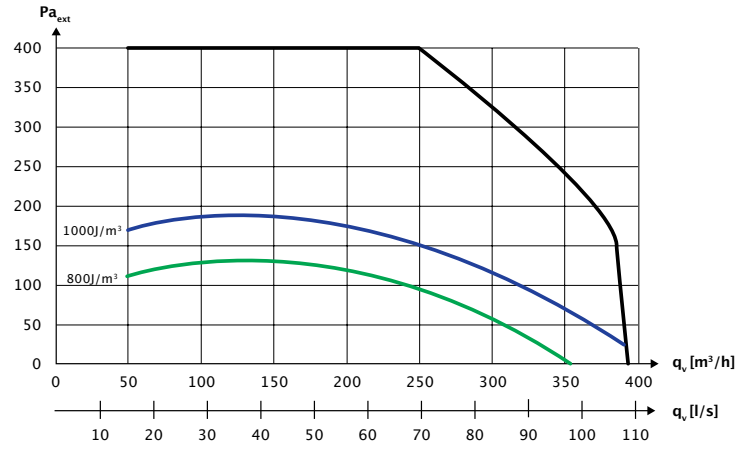

Temperature efficiency

Temperature efficiency for units with counterflow heat exchanger according to EN308 (dry).

Temperature efficiency EN308:

$$\eta_t = (t_{supply\ air} - t_{fresh\ air}) / (t_{extract\ air} - t_{fresh\ air})$$

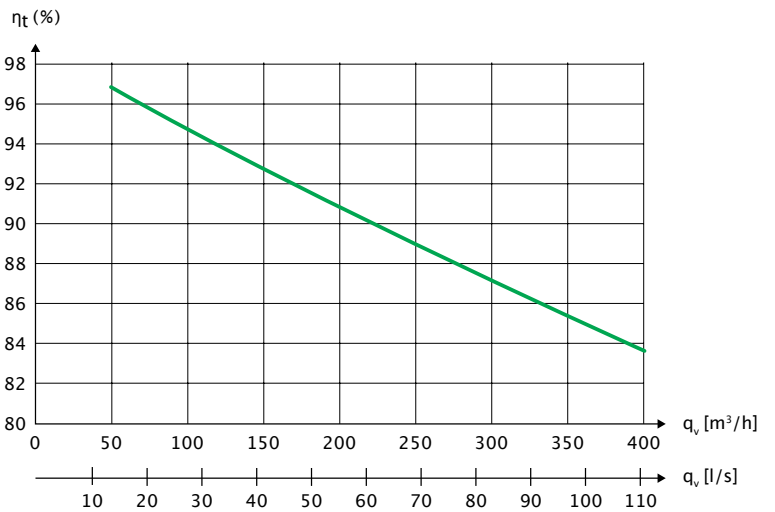

COP (heating)

Heat effect factor COP [-] supply air as function of outdoor temperature [$^{\circ}C$] and volume flow q_v [m^3/h].

According to EN14511, extract air = $21^{\circ}C$.

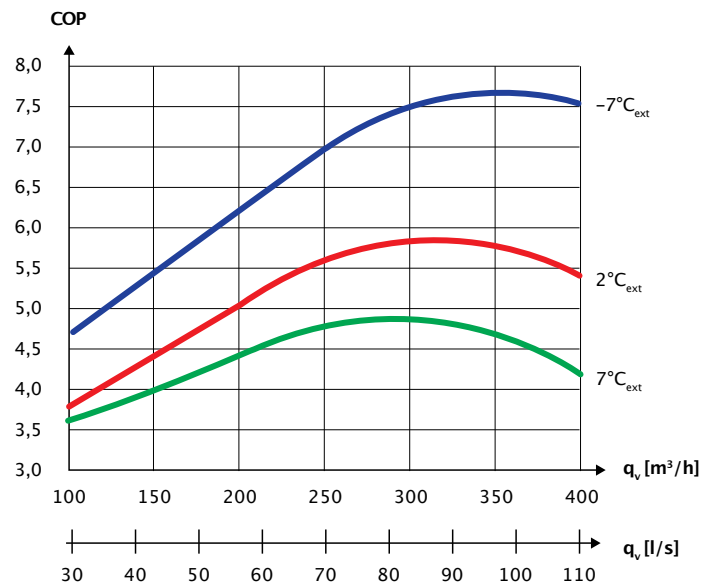

Heat effect (supplyair)

Heat effect Q_c [W] as a function of q_v [m³/h] and fresh air temperature [°C].

According to EN 14511, extract air = 21 °C

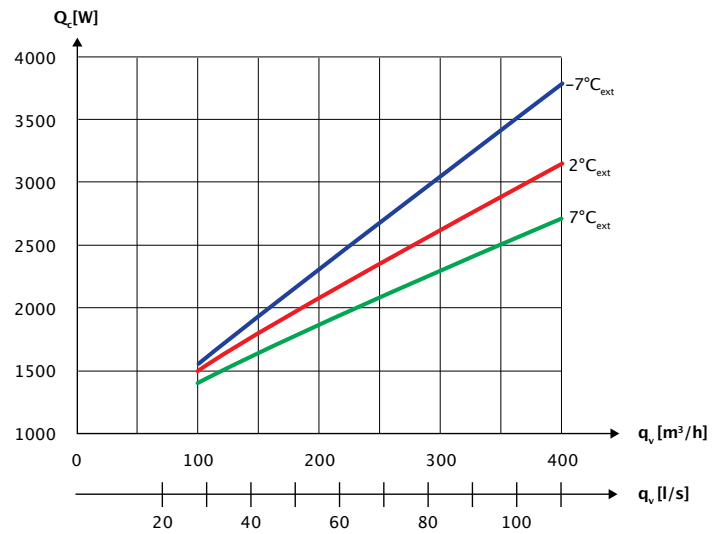

Supply air temperature (heating)

Supply air temperature [°C] as a function of fresh air temperature [°C] and volume flow q_v [m³/h] balanced flow.

Extract air temperature = 21 [°C], 45 RH [%]

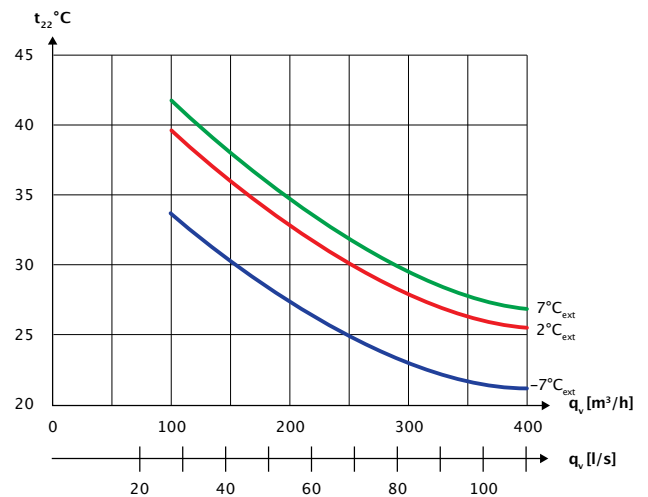

Supply air temperature (cooling)

Supply air temperature [°C] as a function of fresh air temperature [°C] and volume flow q_v [m³/h] balanced flow.

Extract air temperature = 24°C

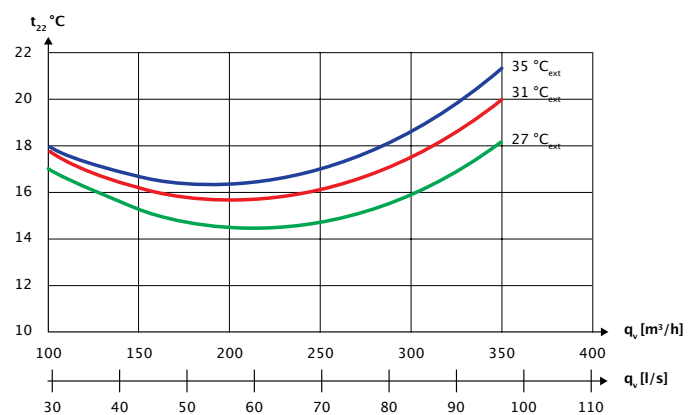

Sound data

Sound data for $q_v = 210$ m³/h and $P_{t,ext} = 100$ Pa according to EN 9614-2 for surfaces and EN 5136 for ducts.

Sound output level L_{WA} drops with falling air volume and falling back pressure.

Sound output level L_{pA} at a given distance will depend on acoustic conditions in the place of installation.

Sound output level (L_{WA})

Octave band Hz	Surface dB(A)	Supply air dB(A)	Extract air dB(A)
125	-	59	46
250	-	66	51
500	-	61	41
1.000	-	56	31
2.000	-	54	28
4.000	-	47	20
Total ±2dB(A)	57	69	53

COMBI 302 POLAR TOP

Product description

Combi 302 Polar Top is a ventilation unit that combines two heat recovery technologies.

Passive heat recovery takes place via a counterflow heat exchanger that utilises between 85% and 95% of the energy in the extracted air. Active heat recovery takes place via a heat pump that utilises the residual energy. The heat pump has a COP > 4, which eliminates the need to install a heating coil with an attached mixing circuit. Combi 302 Polar Top can increase the temperature of the supply air to over 30°C.

The heat pump also makes it possible to cool the supply air in the summer by up to 10°C. Due to the low air exchange, this does not function as an air conditioning system, but cooling the air intake reduces its humidity, giving a more pleasant and comfortable climate inside the home, even when the indoor temperature is high.

Combi 302 Polar Top is delivered with a built-in pre-heating element, which protects the counterflow heat exchanger against icing. This ensures continuous operation at low outdoor temperatures.



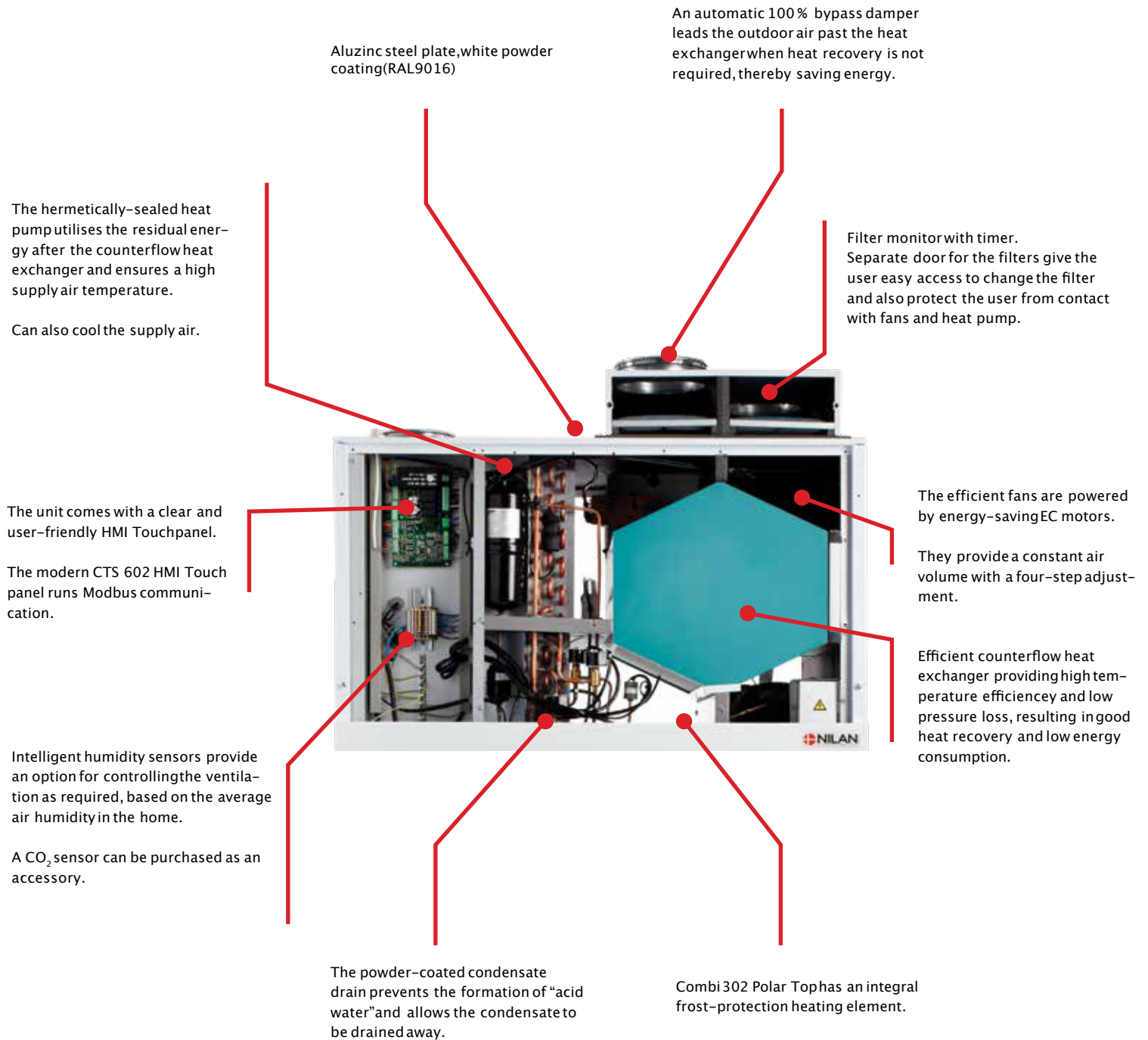

Aluzinc steel plate, white powder coating (RAL9016)

An automatic 100% bypass damper leads the outdoor air past the heat exchanger when heat recovery is not required, thereby saving energy.

The hermetically-sealed heat pump utilises the residual energy after the counterflow heat exchanger and ensures a high supply air temperature.

Can also cool the supply air.

Filter monitor with timer. Separate door for the filters give the user easy access to change the filter and also protect the user from contact with fans and heat pump.

The unit comes with a clear and user-friendly HMI Touchpanel.

The modern CTS 602 HMI Touch panel runs Modbus communication.

The efficient fans are powered by energy-saving EC motors.

They provide a constant air volume with a four-step adjustment.

Intelligent humidity sensors provide an option for controlling the ventilation as required, based on the average air humidity in the home.

A CO₂ sensor can be purchased as an accessory.

Efficient counterflow heat exchanger providing high temperature efficiency and low pressure loss, resulting in good heat recovery and low energy consumption.

The powder-coated condensate drain prevents the formation of "acid water" and allows the condensate to be drained away.

Combi 302 Polar Top has an integral frost-protection heating element.

TECHNICAL SPECIFICATIONS

Combi 302 Polar Top

Dimensions (W x D x H)	900 x 604 x 808 mm
Weight	85 kg
Plate type casing	Aluzinc steel plate, white powder coating RAL9016
Heat loss casing (*1)	32 W / -32 W
Heat exchanger type	Counterflow heat exchanger in combination with a heat pump
Compressor type	Piston compressor
Fan type	EC, constant volume
Filter class	ISO Coarse >90% (G4)
Duct connections	Ø 160 mm
Condensate drain	PVC, Ø 20 x 1,5 mm
Refrigerant	R134a
Refrigerant filling	0.7 kg

External leakage (*2)	<0.54 %
Internal leakage (*3)	<1.71 %
Supply voltage	230 V (±10%), 50/60 HZ
Max. input/power	1.8 kW / 7.8 A
Tightness class	IP31
Standby power	3.2 W
Power consumption build-in preheating element	1.2 kW
Ambient temperature	-20 / +40 °C

*1 32 W: Outdoor air temperature -12 °C. Fitting location -12 °C.
Extract air temperature 20 °C (room).
-32 W: Outdoor air temperature -12 °C. Fitting location 20 °C.
Extract air temperature 20 °C (room).

*2 At ±250 Pa and 300 m³/h according to EN 13141-7.

*3 At ±100 Pa and 300 m³/h according to EN 13141-7.

Dimensional drawing

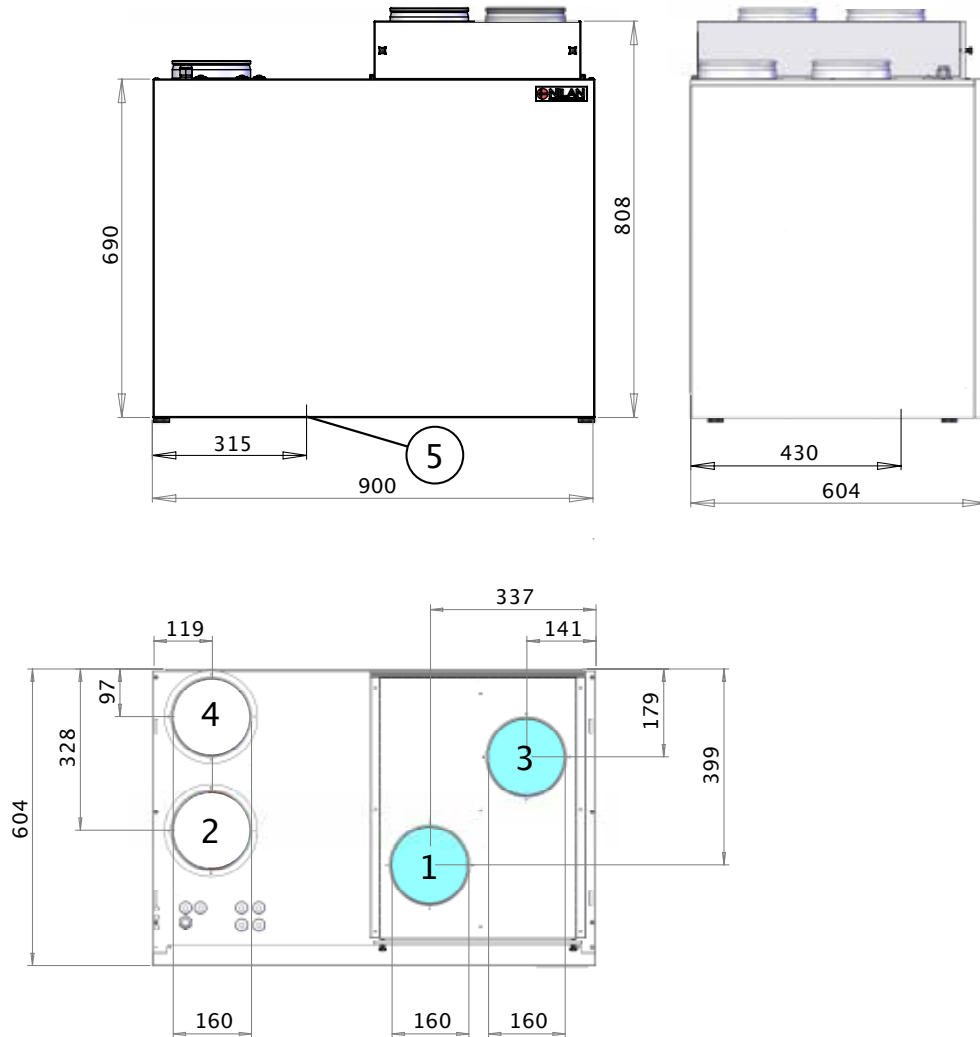

All dimensions are in mm.

Connections

- 1: Fresh air
- 2: Supply air
- 3: Extract air
- 4: Discharge air
- 5: Condensate drain
- 6: Electric supply

Capacity

Capacity of standard unit as a function of q_v and $P_{t,ext}$.

SEL values according to EN 13141-7 are for standard units with ISO Coarse > 90% (G4) filters and without heating element.

Attention! The SEL values are measured and stated as a total value for both fans.

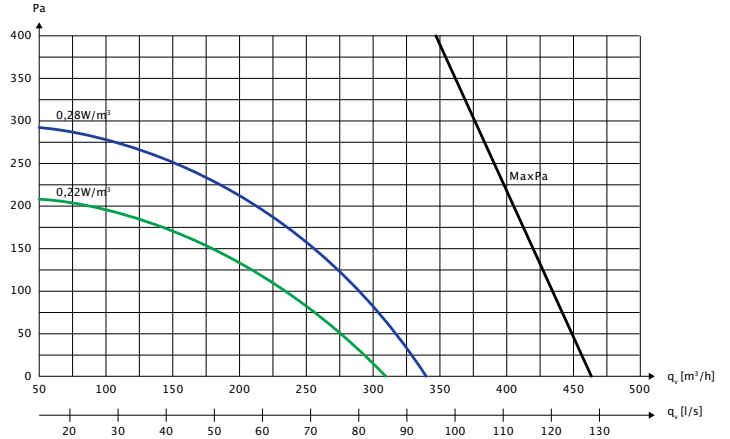

Temperature efficiency

Temperature efficiency for units with counterflow heat exchanger according to EN308 (dry).

Temperature efficiency EN308:

$$\eta_t = (t_{supply\ air} - t_{fresh\ air}) / (t_{extract\ air} - t_{fresh\ air})$$

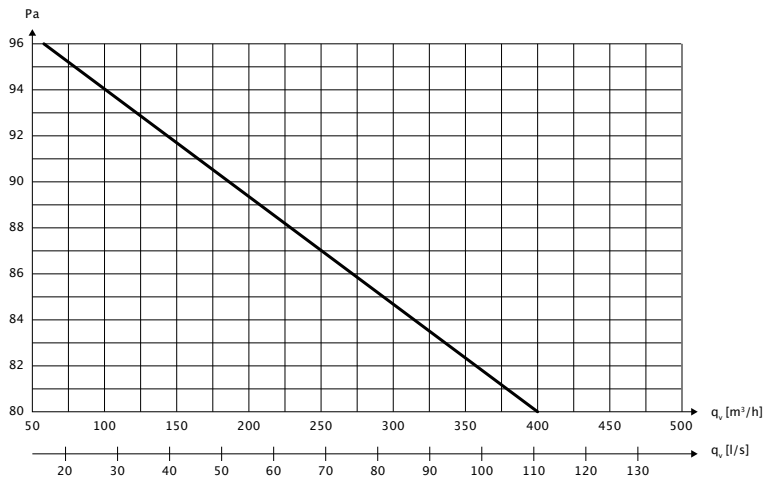

Heat output supply air

Heat output Q_c [W] as a function of q_v [m^3/h] and outdoor air temperature t_{21} [$^{\circ}C$]. In accordance with EN 14511, $t_{11} = 21^{\circ}C$ (extract air)

Heat output is the contribution to room heating added to the fresh air via Combi302 Polar Topto the supply air.

The ventilation loss is the heat output that is lost without heat recovery at the given volume flow air.

--- Ventilation loss
 — Heat output

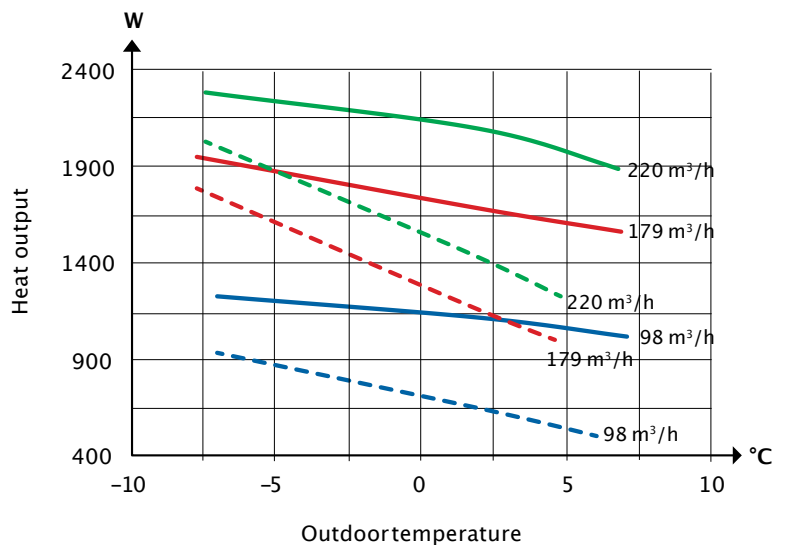

COP (air-air)

Heat output factor COP [-] supply air as a function of outdoor temperature t_{21} [°C] and volume flow q_v [m³/h] in accordance with EN14511 at a room temperature $t_{11} = 21^\circ\text{C}$

COP according EN14511 is calculated for the heat pump and counter flow heat exchanger combined.

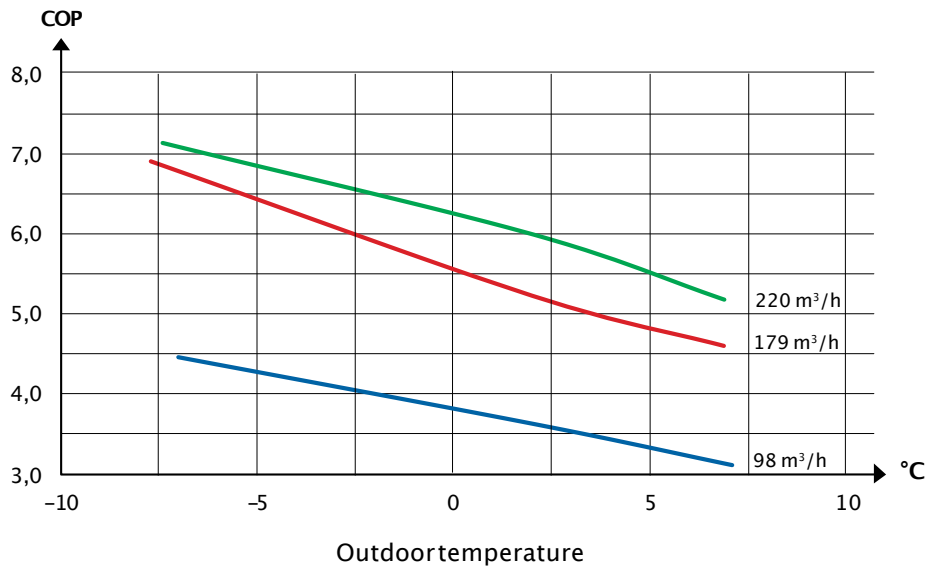

Sound data

Sound data is for $q_v = 210 \text{ m}^3/\text{h}$ and $P_{t,\text{ext}} = 100 \text{ Pa}$ in accordance with EN 9614-2 for surface and EN 5136 for ducts.

Sound output level L_{WA} drops with falling air volumes and falling back-pressure.

At a given distance, the sound pressure level L_{pA} will depend on the acoustic conditions at the installation site.

Sound output level (L_{wa})

Octave band Hz	Surface dB(A)	Supply air dB(A)	Extract air dB(A)
63	-	51	38
125	-	59	46
250	-	66	51
500	-	61	41
1.000	-	56	31
2.000	-	54	28
4.000	-	47	20
8.000	-	40	13
Total ± 2	46	69	53

AUTOMATION

CTS602 Control

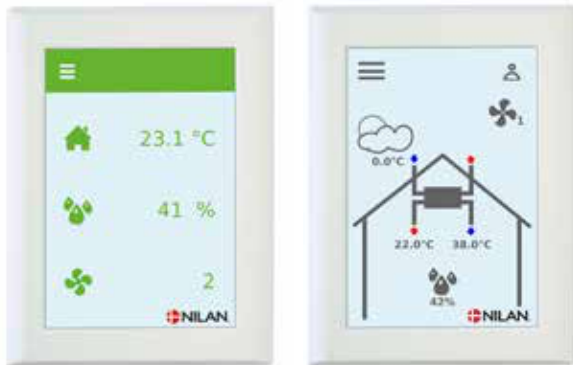

The CTS602 HMI touch panel is featuring a wide range of functions, e.g., menu-controlled operation, weekly programme settings, filter monitor with timer, fan speed adjustment, summer bypass (free cooling), supply-heating element control, error messages etc.

The CTS602 comes with factory settings, including a default setting which can be customised to operational requirements to achieve optimum operation and utilisation of the system.

There is an option for selecting between 2 front page images for the main screen.

Operating instructions for the CTS 602 can be found in a separate user manual supplied with the unit.

Functional diagram

Heating

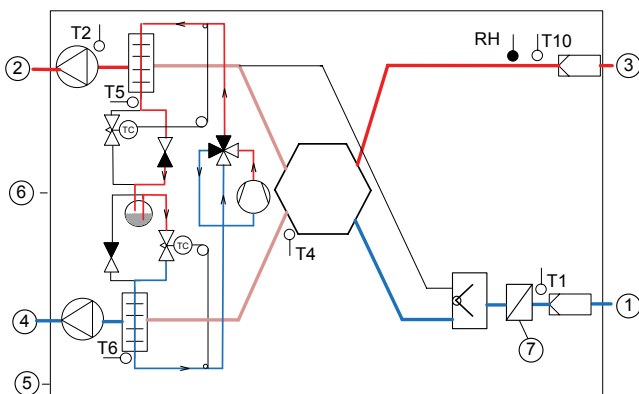

Cooling

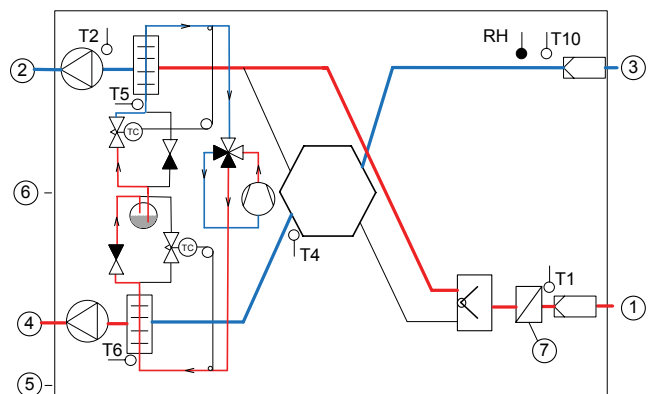

Connections

- 1: Fresh air
- 2: Supply air
- 3: Extract air
- 4: Discharge air
- 5: Condensate drain
- 6: Electrical connection
- 7: Pre-heating element (frost protection)

Automation

- T1: Fresh air sensor
- T2: Supply air sensor
- T4: Discharge air and defrost sensor
- T10: Room sensor/Extract air sensor
- RH: Humidity sensor

Functional overview		+Standard -Accessories
3 levels	The control function is divided into 3 levels:User/Service/Factory with various options at each level	+
Weekly plan	The unit has 3 weekly programmes (with a factory setting of "off") <ul style="list-style-type: none"> •Programme 1: for working families •Programme 2: for stay-at-home families •Programme 3: for businesses There is also an option for you to set your own weekly programme.	+
User option 1	This allows you to override the operating mode in the main menu via an external potential-free contact or PIR sensor.	+
Alarms	Alarm log featuring the last 16 alarms.	+
Filter monitor	Filter monitor with timer (factory setting of 90 days).Adjustable to 30/90/180/360 days.	+
Bypass	Bypassing the outdoor air reduces heat recovery, enabling the desired supply air temperature to be maintained spring, summer and autumn.	+
Air quality	Allows you to choose whether to switch humidity sensors and/or CO ₂ sensors on and off.	+/-
Humidity control	Allows you to set a higher or lower ventilation step in the case of high/low air humidity.	+
CO ₂ control	Allows you to set a higher or lower ventilation step in the case of a high/low CO ₂ level.	-
Air exchange	Allows you to select a low ventilation step in the case of low outside temperatures and air humidity.	+
Temperature control	Allows you to select the temperature sensor which will control the unit. <ul style="list-style-type: none"> •T10 EXHAUST(extract air) 	+
Room low	Stops the unit at a low room temperature. Hereby is cooling of the home avoided in case of a failing central heating system. Standard set to OFF. Can be set from 1 to 20 degrees and is controlled by: <ul style="list-style-type: none"> •T10 EXHAUST(extract air) 	+
Room control	Allows you to set the regulator to control the room temperature.	+
Air volume	Allows you to set four ventilation steps. Supply air and extract air are set individually. Step 1 <25% - Step 2 <45% - Step 3 <70% - Step 4 <100%	+
Fire alarm	This allows you to connect fire-detecting thermostats, smoke detectors and other fire alarm contacts. In case of an alarm, smoke dampers are closed and the unit stops.	+
Joint alarm	Outlet for joint alarm	+
Constant pressure control	Allows control from both the extract air and supply air side.	-
Cooling	The heat pump has a reversible cooling circuit, which means that the cooling circuit can be reversed, with the unit cooling instead of heating the supply air.	+
Intake air control	Allows you to set the regulator to control the intake air temperature/supply air.	+
Delayed start-up	There is a possibility for a delayed start-up by the fans, when a closing damper is installed.	+
Expansion PCB	Allows you to make additional connections, e.g. <ul style="list-style-type: none"> •User option 2 overrides User option 1 (e.g. connecting an EM box) •Up to 500 W direct •Can give the signal for external heating if the defrost function is used •Switching the central heating system on/off 	+
Reset	Allows you to restore the factory settings.	+
Manual test	Allows you to test the unit's functions manually.	+
Language	Option for setting the relevant language (Danish/Finnish/Norwegian/Swedish/German/English/French).	+

COMMUNICATION

External communication

The CTS 602 control unit communicates by default with Modbus RTU RS485 communication. A CTS system using this form of communication can easily be connected to the unit.

Nilan units have an open Modbus communication, i.e. not only can the unit be monitored, but its operation can also be set in the same way as it can via the operating panel.

The protocol is set up by default for a Modbus RTU 30 address, but can be set to a value between 1 and 247.

A Modbus converter allows you to connect one or more units to a computer to monitor and control the unit.

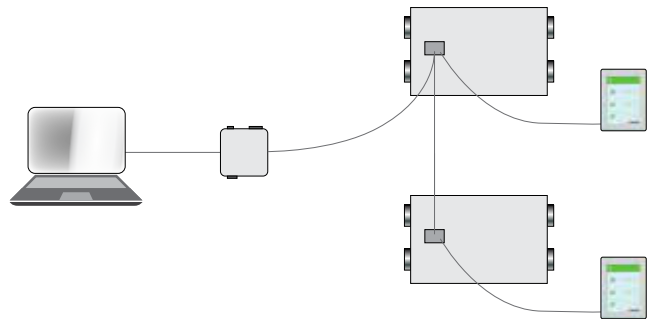

OPERATION

Intelligent humidity control

Nilan's humidity control feature automatically adapts to the needs of the family or the building.

The intelligent CTS 602 control unit does not need to have a set level input for air humidity (RH) to control the air exchange. By using the integrated humidity sensor, the control unit calculates the average level itself for the last 24 hours. The average level provides a basis for deciding whether to change the air exchange if the air humidity fluctuates.

This ensures that the unit always runs at its most efficient, based on the actual air humidity level and not on a theoretical one.

This helps save energy because it automatically adapts to the requirements in the home. Whether a large family or a single person is living in the building has a considerable influence on how much humidity is produced.

The unit also adjusts automatically to summer and winter level.

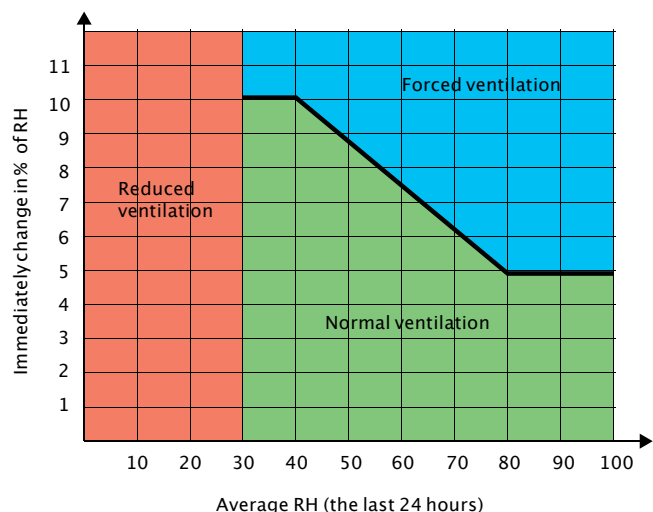

If the air humidity changes by more than 5-10% in relation to the average level, the unit responds with a higher rate of air exchange accordingly.

At an air humidity below 30% is reduced ventilation step activated (adjustable between 15 and 45%)

Frost protection

Nilan CCDI-System (Condition Controlled De-ice System)

Combi 302 Polar Top (with built-in pre-heating element)

Combi 302 Polar (with autonomous pre-heating element) Ensures that the temperature in the outdoor intake does not fall below 0 °C.

Combi 302 Polar Top is controlled by Nilan's unique CCDI (Condition Controlled De-ice) system. This is a very precise, energy-efficient way of ensuring continuous operation of the aggregate right down to -14°C.

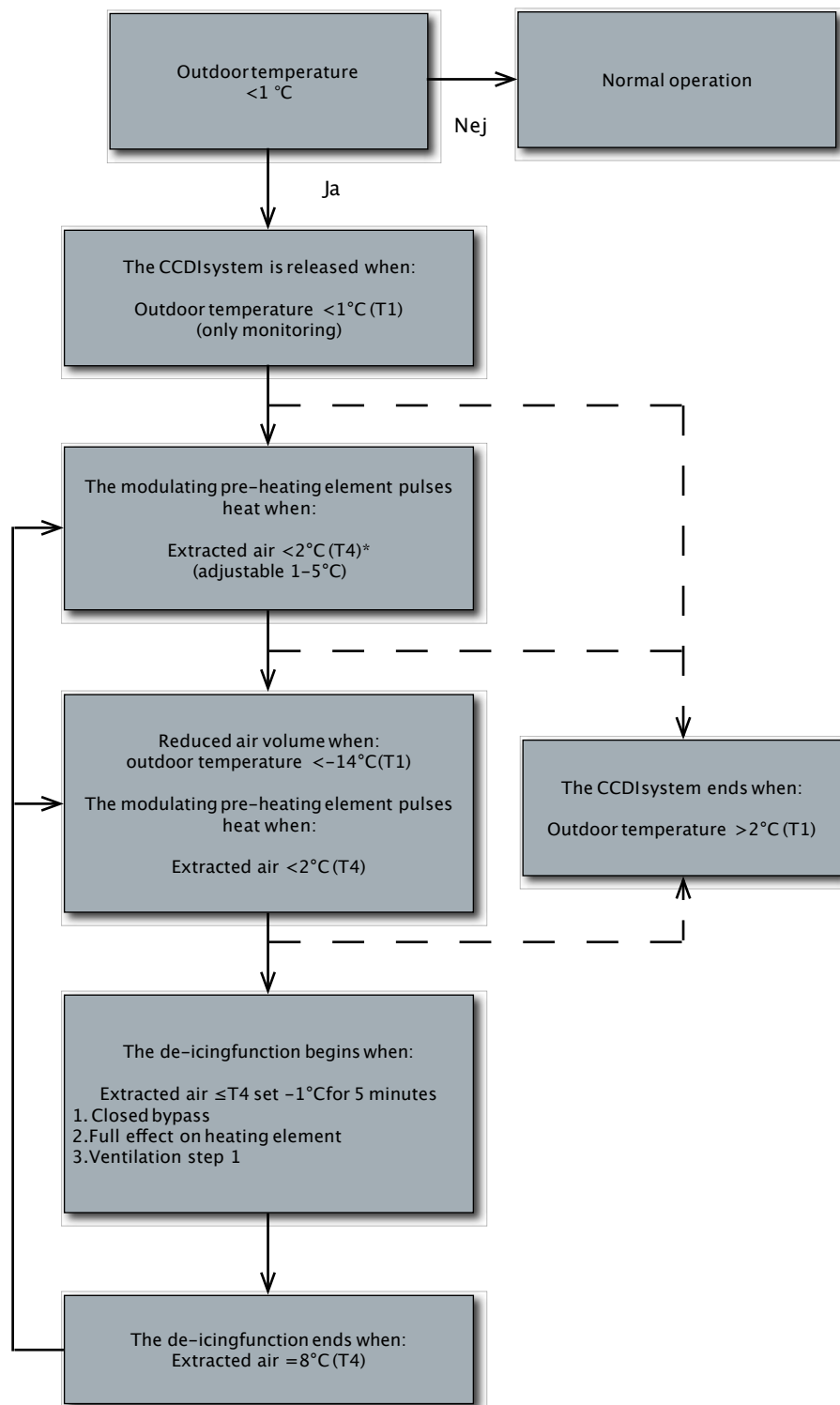

ACCESSORIES



CO₂-sensor

With a CO₂-sensor installed, the ventilation speed can be pre-programmed with CTS 602 to run at a higher ventilation steps when CO₂ reaches high level in the extract air. CO₂-level is programmable.



EM-box

An EM-box allows heat recovery from the air from the range hood and thereby helps to heat the supply air. The EM-box is equipped with a steel filter which efficiently cleans the range hood air of fat particles and thereby protects the system.



Pollen filter ISO ePM1 50-65% (F7)

A pollen filter class ISO ePM1 50-65% (F7) can be fitted in the unit.



Installation kit

The installation kit comprises of four vibration absorbers and a water trap for the condensation outlet. The water trap can be ordered separately.

Heating cable

To protect the condensation outlet against frost, a 3 metre-long self-regulating heating cable can be ordered.

DELIVERY AND HANDLING

Transport and storage

Combi 302 Polar / Combi 302 Polar Top comes in factory packaging that protects it during transport and storage. Combi 302 Polar / Combi 302 Polar Top must be stored in a dry place in its original packaging until installation.

The packaging should only be removed immediately prior to installation.

Installation conditions

During installation, future service and maintenance should be taken into account. We recommend a minimum space in front of the unit of 60 cm.

The unit must be installed level for the sake of the condensate drain. The condensate drain requires clearance of min. 12,5 cm under the drain nozzle.

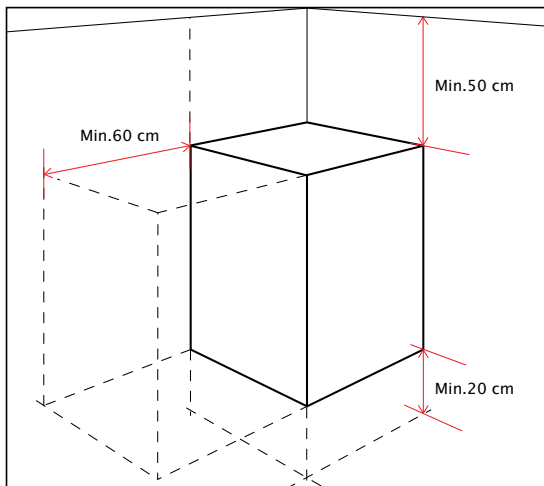

Combi 302 Polar

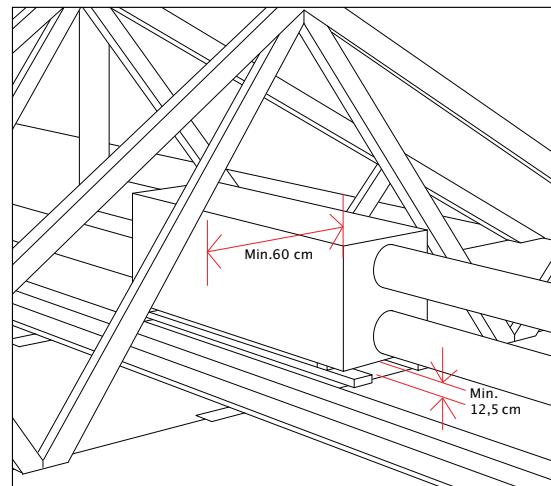

Combi 302 Polar Top

INFORMATION FROM A TO Z

Nilan develops and manufactures premium-quality, energy-saving ventilation and heat pump solutions that provide a healthy indoor climate and low-level energy consumption with the greatest consideration for the environment. In order to facilitate each step in the construction process - from choosing the solution through to planning, installation and maintenance - we have created a series of information material which is available for download at www.nilan.dk.



Brochure

General information about the solution and its benefits.



Product data

Technical information to ensure correct choice of solution.



Installation instructions

Detailed guide for installation and initial adjustment of the solution.



User manual

Detailed guide for regulation of the solution to ensure optimum day-to-day operation.

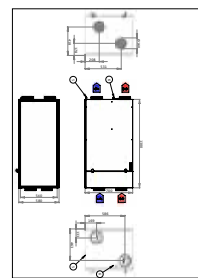

Drawings

Tender documents and 3D drawings are available to download for planning purposes.



Horsham, West Sussex
01403 563045