

PRODUCT DATA

VPL 15 BY NILAN



Horsham, West Sussex
01403 563045



Ventilation & active heat recovery



Domestic



Active
heat recovery



Ventilation
<400 m³/h



Comfort
heating



Comfort
cooling

VPL 15

Product description

VPL 15 is an energy-efficient ventilation unit for heat recovery and cooling of homes and small commercial buildings with a ventilation requirement of up to 400 m³/h.

Heat recovery is via a heat pump that can utilise the recovered energy better than with e.g. a counterflow heat exchanger.

The heat pump has a reversible cooling circuit, which means that the unit can both heat and cool the air.

VPL 15 is supplied fully tested and ready for use. Fitting and commissioning must be carried out by an authorised electrician or plumber.



VPL 15 is supplied with a closed cooling circuit.

The unit can therefore be installed without the help of a cooling technician.



The efficient fans run on low-energy EC motors.



The cooling circuit is driven by a reliable reciprocating compressor.



Intelligent humidity sensors provide an option for controlling the ventilation as required, based on the average air humidity in the home.

A CO₂ sensor can be purchased as an accessory.



Reversible cooling circuit, which means that the heat pump can heat and cool the supply air.



The powder-coated condensate drain prevents the formation of "acid water" and allows the condensate to be drained away.



The option of the FU 15 heat pipe unit with heat pipe will significantly increase the unit efficiency. This can maintain a high intake air temperature without using a heating coil.



Time-controlled alarm for filter exchange. As standard, ISO ePM10 > 50% (M5) filters are provided in extract air and ISO ePM1 50-65% (F7) pollen filters in the outdoor air intake.



The alternative to an FU 15 heat pipe unit is the installation of an external water heater or electrical heating element (accessory).



The unit comes with a clear and user-friendly touch panel. The modern CTS 602 HMI touch panel runs Modbus communication.

Technical specifications

Dimensions (W x D x H)	750 x 415 x 680 mm
Weight	54 kg
Plate type casing	Aluzinc steel plate, white powder coatingRAL9016
Heat loss casing (*1)	32 W / -32 W
Compressor type	Piston compressor
Refrigerant	R134a
Fan type	EC, constant volume
Filter class	ISOePM10 > 50% (M5) / ISOePM1 65-80% (F7)
Duct connections	Ø 160 mm
Condensate drain	PVC, Ø 20x1,5 mm

Supply voltage	230 V (±10%), 50/60 HZ
Max. input/power	720W / 4.3A
Tightness class	IP31
Standby power	3W
Ambient temperature	-20 / +40°C

*1 32 W: Outdoor air temperature -12°C. Fitting location -12°C.
Extract air temperature 20 °C (room).
-32 W: Outdoor air temperature -12°C. Fitting location 20 °C.
Extract air temperature 20 °C (room).

Dimensional drawing

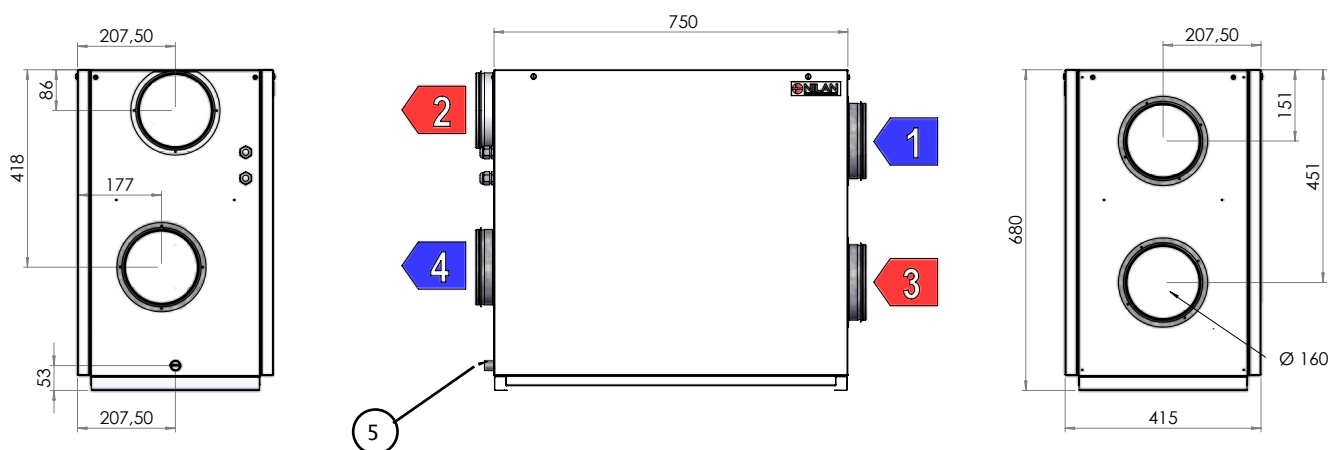

All dimensions are in mm.

The dimension chart is for the left model.
VPL 15 can also be ordered as a right model.

Connections

- 1: Fresh air
- 2: Supply air
- 3: Extract air
- 4: Discharge air
- 5: Condensate drain

FU15

Product description

An option is a FU 15 heat pipe unit with filter, which is connected to the VPL 15 unit.

The heat pipe slightly raises the temperature of the outdoor air, thereby increasing the heat pump's efficiency in the VPL 15 aggregate significantly during the winter.

With an integrated FU 15 heat pipe unit, in most cases there is no need for a heating coil with mixing circuit.



Dimensional drawing

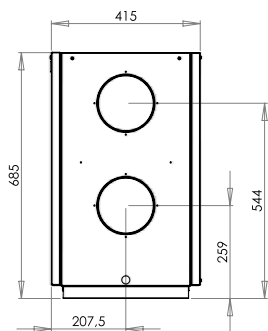

All dimensions are in mm.

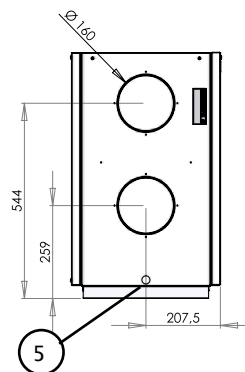
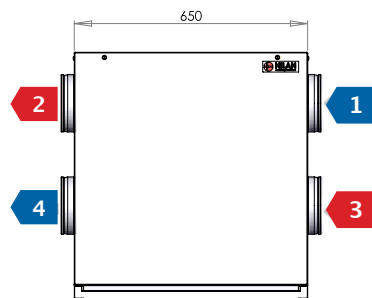

Connections

- 1: Fresh air
- 2: Supply air
- 3: Extract air
- 4: Discharge air
- 5: Condensate drain

Scan the QR code

Scan the QR code with your smartphone or tablet and view a brief film on:

- How the VPL aggregates function
- How efficient heat recovery is
- How the cooling functions



Intelligent humidity control

Nilan's humidity control automatically adapts to the needs of the family or the building.

The intelligent CTS 602 control unit does not need to have a set level input for air humidity (RH) to control the air exchange. By using the integrated humidity sensor, the control unit calculates the average level itself for the last 24 hours. The average level provides a basis for deciding whether to change the air exchange if the air humidity fluctuates.

This ensures that the unit always runs at its most efficient, based on the actual air humidity level and not on a theoretical one.

This helps save energy because it automatically adapts to the requirements in the home. Whether a large family or a single person is living in the building has a considerable influence on how much humidity is produced.

The unit also adjusts automatically to summer and winter level.

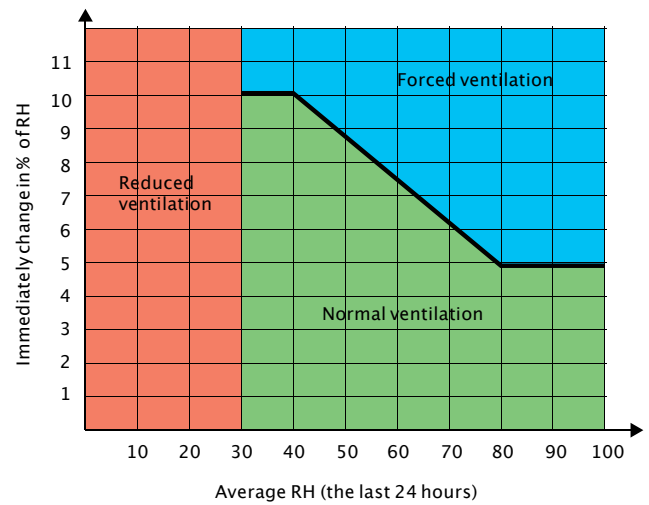

If the air humidity changes by more than 5–10% in relation to the average level, the unit responds with a higher rate of air exchange accordingly.

At an air humidity below 30% is reduced ventilation step activated (adjustable between 15 and 45%)

COMMUNICATION

External communication

The CTS 602 control unit communicates by default with Modbus RTU RS485 communication. A CTS system using this form of communication can easily be connected to the unit.

Nilan units have an open Modbus communication, i.e. not only can the unit be monitored, but its operation can also be set in the same way as it can via the operating panel.

The protocol is set up by default for a Modbus RTU 30 address, but can be set to a value between 1 and 247.

A Modbus converter allows you to connect one or more units to a computer to monitor and control the unit.

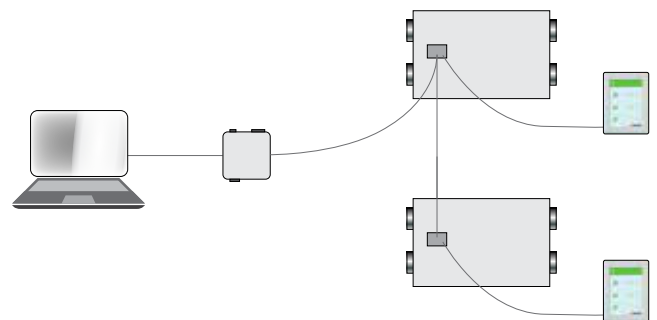

PLANNING DATA

Capacity

MaxPa capacity of standard unit, $P_{t,ext}$ as a function of q_v , with regard to SEL-values.

SEL-values according to EN13414-7 for a standard unit with ISO ePM10 >50% (M5) and ISO ePM1 65-80% (F7) filters and no heating element.

SEL values comprise the unit's total power consumption incl. control.

Conversion factor: $\frac{J/m^3}{3600} = W/m^3/h$

Attention! The SEL values are measured and stated as a total value for both fans.

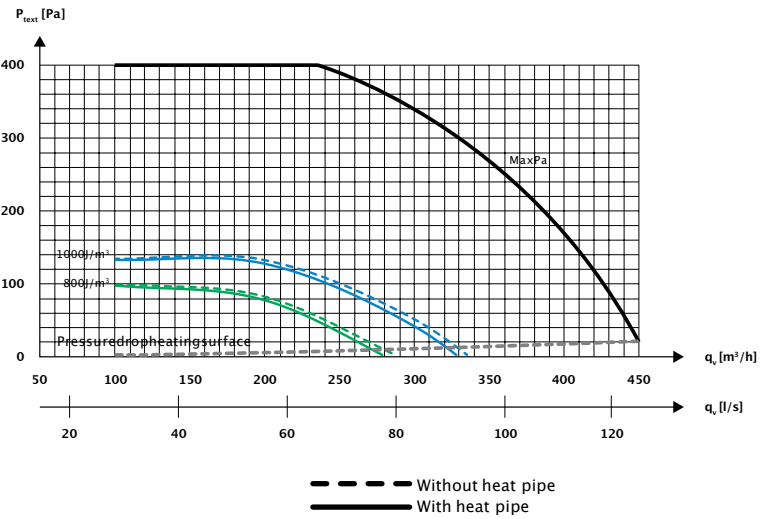

COP (heating)

Heat effect factor COP [-] supply air as function of outdoor temperature [$^{\circ}C$] and volume flow q_v [m^3/h].

According to EN14511, extract air = $21^{\circ}C$.

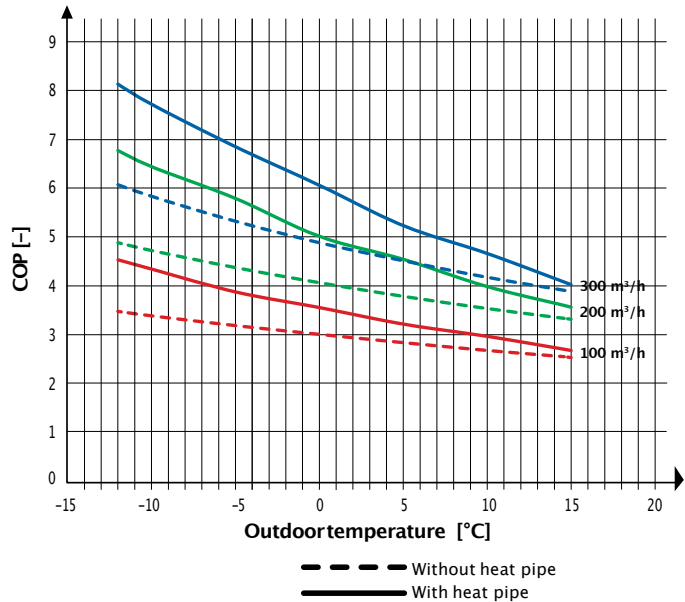

Heat effect (supply air)

Heat effect Q_c [W] as a function of q_v [m^3/h] and fresh air temperature [$^{\circ}C$].

According to EN 14511, extract air = $21^{\circ}C$

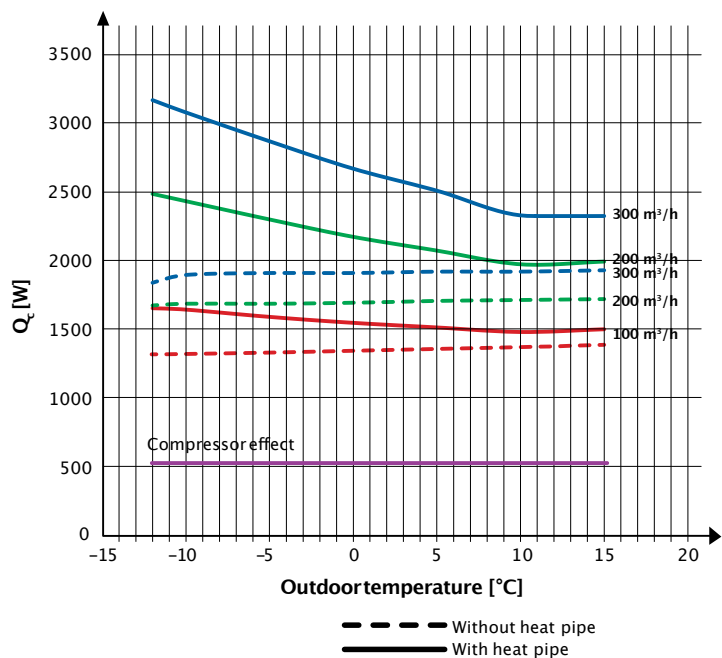

Supply air temperature (heating)

Supply air temperature [°C] as a function of fresh air temperature [°C] and volume flow q_v [m³/h] balanced flow.

Extract air temperature = 21 [°C], 45 RH [%]

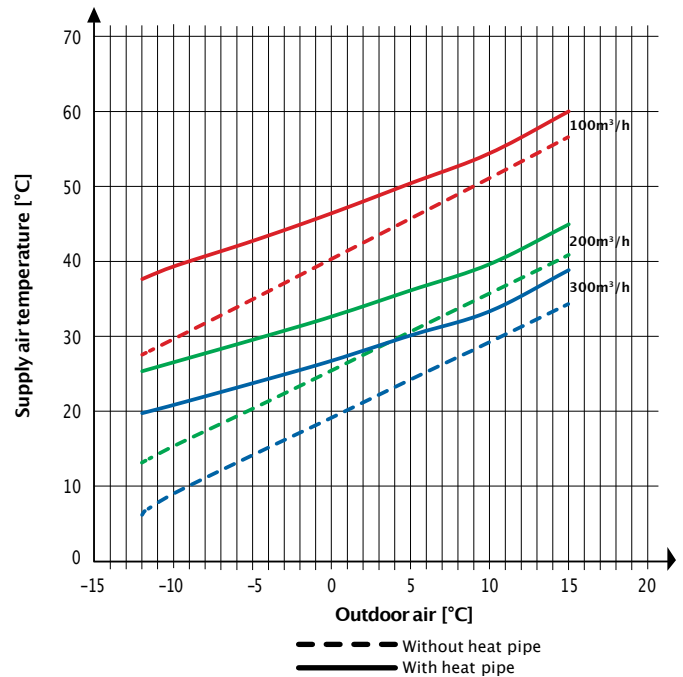

Supply air temperature (cooling)

Supply air temperature [°C] as a function of fresh air temperature [°C] and volume flow q_v [m³/h] balanced flow.

Extract air temperature = 24°C

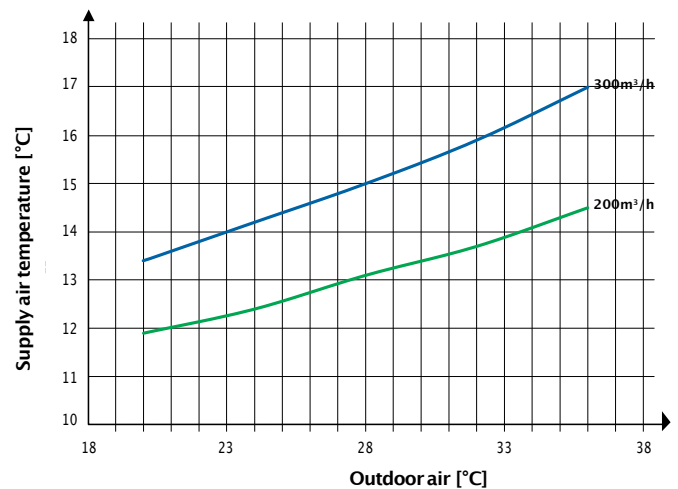

Sound data

Sound data for $q_v = 210$ m³/h and $P_{t,ext} = 100$ Pa according to EN 9614-2 for surfaces and EN 5136 for ducts.

Sound output level L_{WA} drops with falling air volume and falling back pressure.

Sound output level L_{pA} at a given distance will depend on acoustic conditions in the place of installation.

Sound output level (L_{WA})

Octave band Hz	Surface dB(A)	Supply air dB(A)	Extract air dB(A)
125	48	50	49
250	46	55	54
500	38	58	57
1.000	35	57	56
2.000	29	58	57
4.000	25	58	57
Total ±2dB(A)	50	64	63

AUTOMATION

CTS 602 Control

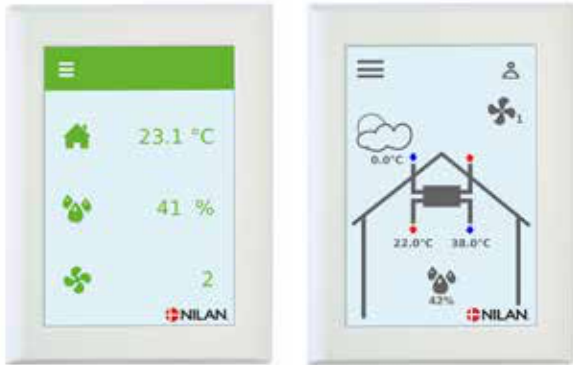

The VPL15 is controlled using its CTS 602 HMI touch panel, featuring a wide range of functions, e.g., menu-controlled operation, weekly programme settings, filter monitor with timer, fan speed adjustment, summer bypass (free cooling), supply-heatingelement control, error messages etc.

The CTS 602 comes with factory settings, including a default setting which can be customised to operational requirements to achieve optimum operation and utilisation of the system.

There is an option for selecting between 2 front page images for the main screen.

Operating instructions for the CTS 602 can be found in a separate user manual supplied with the unit.

Functional diagrams

Heating

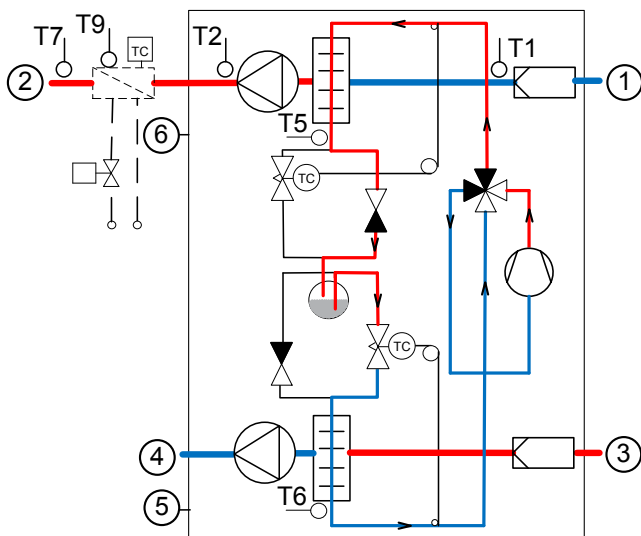

Cooling

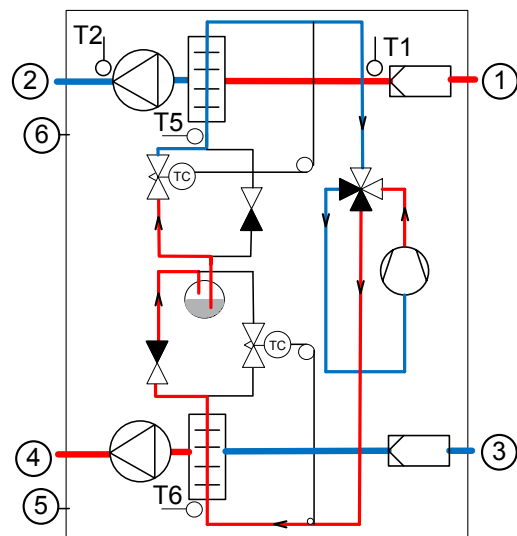

Connections

- 1: Fresh air
- 2: Supply air
- 3: Extract air
- 4: Discharge air
- 5: Condensate drain
- 6: Electric and water heating

Automatik

- T1: Outdoor air sensor
- T2/T7: Supply air sensor
- T9: Heating element frost protection
- T5: Capacitor sensor
- T6: Evaporator sensor
- T10: Room sensor

Functional overview		+Standard -Accessories
3 levels	The control function is divided into 3 levels:User/Service/Factory with various options at each level	+
Weekly plan	The unit has 3 weekly programmes (with a factory setting of "off") <ul style="list-style-type: none"> •Programme 1: for working families •Programme 2: for stay-at-home families •Programme 3: for businesses There is also an option for you to set your own weekly programme.	+
User option 1	This allows you to overwrite the operating mode in the main menu via an external potential-free contact or PIR sensor.	+
User option 2	With expansionPCB: <ul style="list-style-type: none"> •User option 2 overrides User option 1 (e.g. connecting an EM box) •Up to 500 W direct •Can give the signalfor external heating if the defrost function is used •Switching the central heating system on/off 	-
Alarms	Alarm log featuring the last 16 alarms.	+
Filter monitor	Filter monitor with timer (factory setting of 90 days).Adjustable to 30/90/180/360days.	+
Bypass	Bypassing the outdoor air reduces heat recovery,enabling the desired supply air temperature to be maintained spring, summer and autumn.	+
Air quality	Allows you to choose whether to switch humidity sensors and/or CO ₂ sensors on and off.	-
Humidity control	Allows you to set a higher or lower ventilation step in the case of high/lowair humidity.	+
CO ₂ control	Allows you to set a higher or lower ventilation step in the case of a high/lowCO ₂ level.	-
Air exchange	Allows you to select a low ventilation step in the case of low outside temperatures and air humidity.	+
Frostprotection	In case of failingheating system,the unit is turned off to avoid further coolingwith a risk of the water heating coilfrost bursting.	+
Temperature control	Allows you to select the temperature sensor which will control the unit. <ul style="list-style-type: none"> •T10 EXT(fitted in a representative extraction valve) 	+
Room low	Stops the unit at a low room temperature.Hereby is coolingof the home avoided in case of a failingcentral heating system.Standard set to OFF.Can be set from 1 to 20 degrees and is controlled by: <ul style="list-style-type: none"> •T10 EXT(fitted in a representative extraction valve) 	+
Room control	Allows you to set the regulator to control the room temperature.	+
Air volume	Allows you to set four ventilation steps.Supply air and extract air are set individually. Step 1 <25% - Step 2 <45% - Step 3 <70% - Step 4 <100%	+
Fire alarm	This allows you to connect fire-detectingthermostats,smoke detectors and other fire alarm contacts.In case of an alarm,smoke dampers are closedand the unit stops.	+
Jointalarm	Outlet for jointalarm	+
Constant pressure control	Allows control from both the extract air and supply air side.	-
Cooling	The heat pump has a reversible coolingcircuit,which means that the coolingcircuitcan be reversed,with the unit coolinginstead of heating the supply air.	+
Intake air control	Allows you to set the regulator to control the intake air temperature/supply air (only available if the control unit has been configured for a supply-heatingelement).	+
External heating element	<ul style="list-style-type: none"> •Temperature sensor T7 is an supply air sensor •Integrated frost protection for external water heating element •Motorised valve and circulation pump control unit 	-
External electric heating element	<ul style="list-style-type: none"> •Temperature sensor T7 is an supply air sensor •Overheating protection 	-
Delayed start-up	There is a possibility for a delayed start-upby the fans,when a closingdamper is installed.	+
Reset	Allows you to restore the factory settings.	+
Manual test	Allows you to test the unit'sfunctions manually.	+
Language	Option for setting the relevant language (Danish/Finnish/Norwegian/Swedish/German/English/French).	+

ACCESSORIES



CO₂-sensor

With a CO₂-sensor installed, the ventilation speed can be pre-programmed with CTS 602 to run at a high ventilation steps when CO₂ reaches high level in the extract air. CO₂-level is programmable.



Water heating element incl. regulation

The supply temperature can always be raised to the required level using a water heating element. The water heating element is designed to be built into the duct and must be connected to the primary heating supply. Supplied with two-way adjustment valve, temperature sensor and frost thermostat.



Electrical heating surface incl. regulation

When you fit an electrical heating surface, you can raise the fresh air temperature to the desired level at any time. The electrical heating surface is supplied ready to fit into the fresh air duct and, for easy fitting, the device is pre-fitted with all the required sensors.



EM-box

An EM-box allows heat recovery from the air from the range hood and thereby helps to heat the supply air. The EM-box is equipped with a special filter which efficiently cleans the range hood air of fat particles and thereby protects the system.



Expansion PCB

The expansion PCB provides additional functions for the CTS 602 control unit, e.g., controlling the EM box (see list of functions on page 9).



Installation kit

The installation kit comprises of four vibration absorbers and a water trap for the condensation outlet. The water trap can be ordered separately.

Heating cable

To protect the condensation outlet against frost, a 3 metre-long self-regulating heating cable can be ordered.

DELIVERY AND HANDLING

Transport and storage

VPL 15 comes in factory packaging that protects it during transport and storage.

VPL 15 must be stored in a dry place in its original packaging until installation.

The packaging should only be removed immediately prior to installation.

Installation conditions

When installing, plan ahead for service and maintenance. We recommend minimum clearance in front of the unit of 60 cm.

Ensure the unit is level, with regard to the condensation drain. The condensation drain requires clearance of min. 10.5 cm under the drain spout.

Use a flexible connection between the unit's nozzle and duct system.

The unit is quiet and low vibration, but the fact that vibrations can still be transmitted to the building fabric should be taken into account. We recommend a minimum distance of 30 mm to the building fabric and other fixtures. We recommend erecting the unit on vibration dampers to separate it from the surface it stands on.

Installation of electric heating element

Electric heating elements (accessories) are fitted in the duct. The heating element must be insulated using fire-resistant insulation material.

The electric heating element must be connected by an authorised electrician.

VPL 15

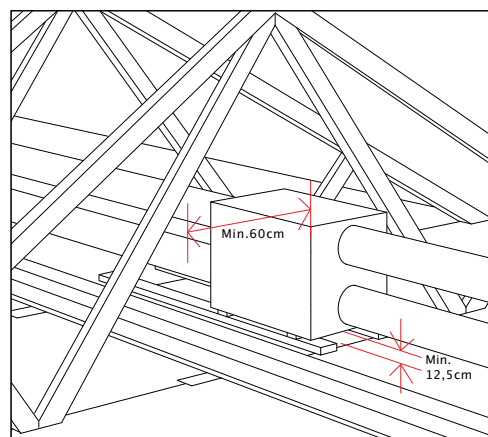

VPL 15 + FU 15

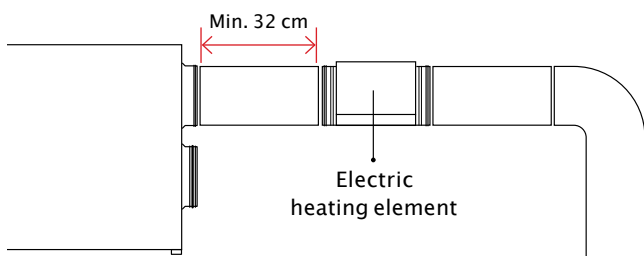
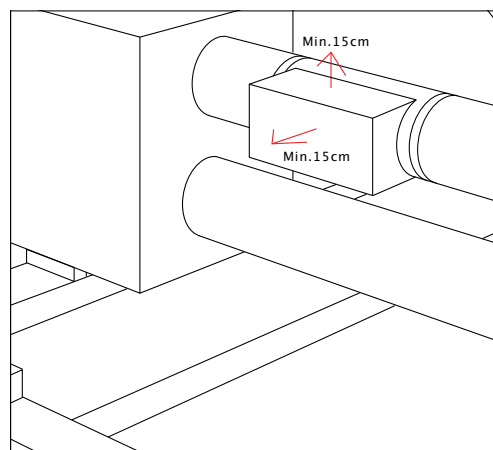
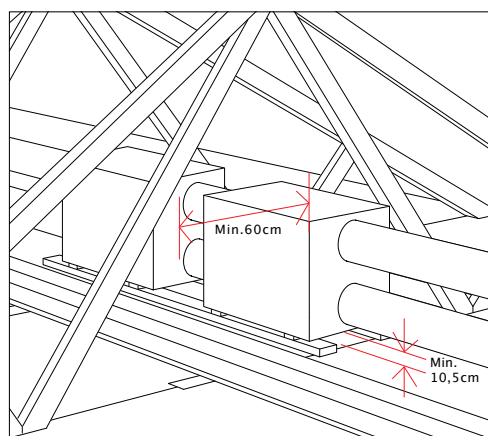

INFORMATION FROM A TO Z

Nilan develops and manufactures premium-quality, energy-saving ventilation and heat pump solutions that provide a healthy indoor climate and low-level energy consumption with the greatest consideration for the environment. In order to facilitate each step in the construction process - from choosing the solution through to planning, installation and maintenance - we have created a series of information material which is available for download at www.nilan.dk.



Brochure

General information about the solution and its benefits.



Product data

Technical information to ensure correct choice of solution.



Installation instructions

Detailed guide for installation and initial adjustment of the solution.



User manual

Detailed guide for regulation of the solution to ensure optimum day-to-day operation.

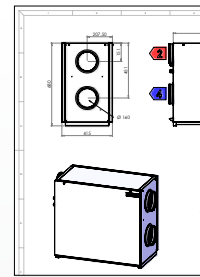

Drawings

Tender documents and 3D drawings are available to download for planning purposes.



Horsham, West Sussex
01403 563045

www.slservicesgroup.com